

Diterima	: 27 Mei 2024
Direvisi	: 27 Juni 2024
Disetujui	: 29 Juni 2024
Diterbitkan	: 30 Juni 2024

PENGARUH KECERDASAN EMOSIONAL TERHADAP KEPUASAN KERJA YANG DIMEDIASI OLEH EFIKASI DIRI (Studi pada Sekolah Dasar Negeri di Desa Nanga Wera)

Herdiman¹, Susanto Tirtoprojo²

¹herdiman019@gmail.com, ²susantotp57@staff.uns.ac.id

Program Studi Manajemen Sumber Daya Manusia, Universitas Sebelas Maret Surakarta

Abstrak: Penelitian ini menyelidiki pengaruh kecerdasan emosional terhadap kepuasan kerja yang dimediasi oleh efikasi diri. Penelitian ini dilakukan pada guru SD Negeri di Desa Nanga Wera Kecamatan Wera Kabupaten Bima. Data dikumpulkan dengan menggunakan pendekatan survei online. Responden pada penelitian ini adalah guru yang bekerja di sekolah dasar negeri di desa Nanga Wera kecamatan Wera Kabupaten Bima. Jumlah responden penelitian ini adalah 52 orang dan diidentifikasi menggunakan kuesioner online. Software SmartPLS digunakan untuk melakukan analisis data regresi statistik. Hasil penelitian menunjukkan bahwa ada hubungan positif yang signifikan antara kecerdasan emosional guru dengan kepuasan kerja, dan efikasi diri mempunyai pengaruh mediasi yang signifikan terhadap hubungan kecerdasan emosional dengan kepuasan kerja.

Kata-kata Kunci: Kecerdasan Emosional, Kepuasan Kerja, Efikasi Diri

THE INFLUENCE OF EMOTIONAL INTELLIGENCE ON JOB SATISFACTION MEDIATED BY SELF-EFFICACY (Study at State Elementary School in Nanga Wera Village)

Abstract: This research investigates the influence of emotional intelligence on job satisfaction which is mediated by self-efficacy. This research was conducted on state elementary school teachers in Nanga Wera Village, Wera District, Bima Regency. Data was collected using an online survey method. The respondents in this investigation were educators who taught at state primary educational institutions in Nanga Wera village, Wera subdistrict, Bima Regency. The number of respondents to this study was 52 people and were identified using an online questionnaire. Data analysis was carried out using a statistical regression approach using SmartPLS software. The research results show that there is a significant positive influence between teacher emotional intelligence and job satisfaction, and self-efficacy has a significant mediating influence on how job satisfaction and emotional intelligence are related.

Keywords: Emotional Intelligence, Job Satisfaction, Self-Efficacy

INTRODUCTION

Education is one area that is greatly influenced by emotional factors. Among all components in the education system, (Abebe & Singh, 2023). The teacher's role is crucial in directing and guiding students. However, the pressure and challenges experienced by teachers in carrying out their duties can

affect their job satisfaction. In this context, emotional intelligence emerges as a factor that plays an important role in influencing teacher job satisfaction. Self-efficacy, as a teacher's belief in his or her ability to overcome challenges and achieve goals, has been identified as a mediator in the relationship between emotional intelligence and job satisfaction (Capone et al., 2023). In

this format, it investigates the concepts of emotional intelligence, teacher job satisfaction, self-efficacy, and the relationship between the two.

Emotional intelligence refers to a person's ability to understand, manage, and express emotions appropriately in a variety of situations. This concept was first proposed by Peter Salovey and John D. Mayer in the 1990s (Tcharkhalashvili, 2023), and expanded in 1995 by Daniel Goleman's famous book 'Emotional Intelligence'. (Muhammad Habib et al., 2023) Emotional intelligence includes several main components: First, Emotional Understanding is the ability to recognize, understand, and express emotions appropriately (Igbokwe et al., 2023). Second, emotional management is the ability to manage and manage emotions in oneself and others (Nicolae Brînzea, 2022). Third, empathy is the ability to recognize and understand other people's emotions and respond to them with appropriate compassion (Sharief, 2022). Fourth, Social Skills: The ability to interact with other people effectively, build healthy relationships, and resolve conflicts well. Fifth, emotional intelligence is believed to have a substantial effect on some life, including in work contexts, such as the teaching profession.

In the field of education, teacher emotional intelligence plays an important role in facilitating interactions between teachers and students and creating a positive learning environment (Tcharkhalashvili, 2023). Teachers who have been highly emotionally intelligent can understand and respond to students' emotional needs better, creating an environment that supports their social and emotional development (Kanbur & Kirikkaleli, 2023). They are also able to better manage stress and conflict, which is an integral part from a healthy learning environment (Muhammad Habib et al., 2023). Research shows that teachers' emotional intelligence is related to the quality of their interactions with students, effective teaching, and student's satisfaction with their teaching (Anh & Huy, 2022). Teachers who can recognize and manage emotions well tend to be better able to create an inclusive and supportive learning climate (Valente et al., 2022) They can also be more effective in handling conflicts and challenges that arise in the classroom environment.

Teacher job satisfaction refers to

teachers' positive evaluation of their work. This includes aspects such as satisfaction with relationships with students, satisfaction with the work environment, and satisfaction with working conditions in general. Teacher job satisfaction has important implications in the educational context. Instructors who are happy with their profession are typically more driven to provide students with the greatest instruction and guidance possible. They are also more likely to stay in their profession and experience fewer symptoms of stress and burnout. Apart from that, teacher job satisfaction can also have a favorable effect on the standard of instruction and the learning outcomes of students (Cabaron & Oco, 2023).

Teacher self-efficacy refers to the teacher's belief in his ability to overcome challenges and achieve goals in the context of teaching and mentoring (Lingán-Huamán, 2023). This concept was introduced by Albert Bandura in his self-efficacy theory in 1977 and has become the main focus in educational psychology (Yentur, 2023). Teacher self-efficacy plays an important role as a mediator in the relationship between teachers' emotional intelligence and their job satisfaction (Feng et al., 2023).

Teachers with high emotional intelligence tend to have a positive impact on self-efficacy (Syamsu, 2017). They will be better able to overcome challenges and stress at work, which may have an impact on increasing job satisfaction (Sampan & Caballes, 2023). Furthermore, self-efficacy can strengthen the relationship between teacher emotional intelligence and job satisfaction by mediating the positive influence of emotional intelligence on job satisfaction.

Theories and research from earlier periods have revealed a complex correlation between teacher job satisfaction, emotional intelligence, and self-efficacy. High emotional intelligence can increase teachers' self-efficacy by helping them manage emotions, cope with stress, and build healthy relationships with students and colleagues. Teachers who believe in their ability to teach and guide students tend to be more satisfied with their jobs. On the other hand, self-efficacy can also mediate the relationship between teachers' emotional intelligence and their job satisfaction. Teachers who have high emotional intelligence tend to have higher self-efficacy, which in turn can

increase teacher job satisfaction (Chauhan et al., 2022).

The number of public elementary schools in Nanga Wera village is 2 schools, this indicates that the basic education infrastructure in the village is increasingly developing. With more schools, children in Nanga Wera village have more options to receive quality education without having to travel far. This not only increases the accessibility of education but also strengthens the educational foundation for their future and the growth of the community as a whole. However, there is a phenomenon related to teacher job satisfaction that is of concern amidst the positive development of basic education infrastructure. Even though the number of schools is increasing, teacher job satisfaction is not always in line with the growth of physical infrastructure. Some teachers face challenges in terms of working conditions, adequate administrative support, or the need for better professional development. Therefore, it is important not only to pay attention to the physical development of the educational infrastructure, but also to the lives of teachers, who are the pillars of providing quality education to the children of Nanga Wera village. If this is not taken seriously, there will likely be negative impacts that could affect the overall quality of education.

Teachers' lack of job satisfaction can impact their motivation to provide quality teaching, cause instability in the classroom environment, and even potentially reduce students' interest in learning (Tirana et al., 2023). In addition, if the needs of educators are not properly met, there could be a decrease in the number of committed teachers and potentially an increase in teacher turnover rates, which could ultimately be detrimental to continuity and consistency in the education process (McJames et al., 2023). Therefore, related parties need to pay serious attention to teacher welfare and job satisfaction as an integral part of efforts to improve the quality of education in Nanga Wera village.

RESEARCH METHODS

The nature of this research is quantitative, the quantitative approach involves testing hypotheses by examining the relationships between variables. These variables can then be measured using tools so that all data can be

obtained and analyzed using statistical methods (Creswell, & Creswell, 2017).

The subjects in this research were 52 teachers who worked at state elementary schools in Nanga Wera village. In this research, a survey was used to obtain data on three variables: emotional intelligence (X), job satisfaction (Y), and self-efficacy (Z). All variables were met by a sample of state elementary school teachers in Nanga Wera Village, Wera District, Bima Regency. Because the number of samples is the same as the population and the population is <100, the sampling technique was used entirely using the random sampling method. Therefore, the collection is carried out by taking samples of the entire population.

In analyzing the data used in this research, smarPLS 3.0 software was used which was run on a computer, and Least Squares (PLS) analysis was used. There are three stages in Smart-PLS analysis, including external model analysis, internal model analysis, and hypothesis testing.

RESULTS AND DISCUSSION

Result

Outer Model Analysis

Extrinsic pattern analysis or model is a model that explains how each variable that appears in the form of a signal or instrument is associated with the latent variable. External sample analysis was carried out to determine the validity and accuracy of the data.

Structural Model Analysis

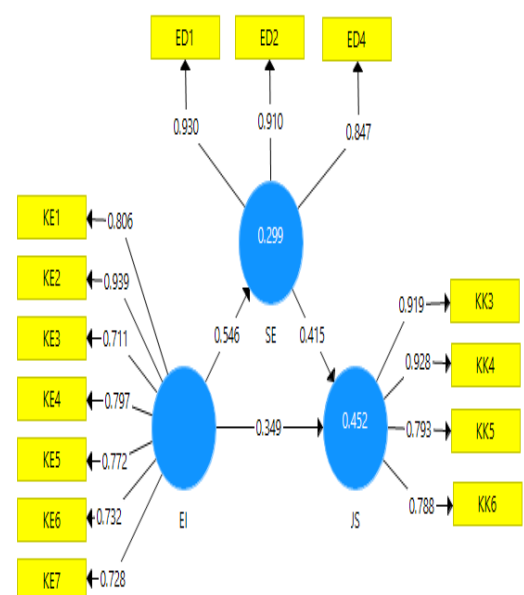

A structural model is a model regarding the structure of relationships that forms or explains the relationship between variables. The following is a structural model obtained

from SEM-PLS management regarding emotional intelligence (EI), job satisfaction (JS), and self-efficacy (SE).

Figure 1. Outer model graph

Source: Processed primary data, SmartPLS 3.0 output (2024).

Validity Test

Validity testing in this research was carried out by observing the convergent validity, discriminant validity, and AVE values.

Table 1. Convergent Validity

	EI	JS	SE
EI.1	0,806		
EI.2	0,939		
EI.3	0,711		
EI.4	0,797		
EI.5	0,772		
EI.6	0,732		
EI.7	0,728		
JS.1		-	
JS.2		-	
JS.3		0,919	
JS.4		0,928	
JS.5		0,793	
JS.6		0,788	
SE.1			0,930
SE.2			0,910
SE.3			-
SE.5			0,847

Source: Processed primary data, SmartPLS 3.0 output (2024)

The test results are shown in Table 1. Because it is known that 3 value items have an outer loading <0.7, these questions will be removed or not used in the next test. After extraction, all other factors have loading values above the required value, namely 0.7, which means the factors used in this research are valid or have met the requirements for convergent validity.

Table 2. Discriminant validity

	EI	JS	SE
EI.1	0,806	0,474	0,422
EI.3	0,711	0,381	0,383
EI.4	0,797	0,419	0,388
EI.5	0,772	0,333	0,451
EI.6	0,732	0,406	0,427
EI.7	0,728	0,559	0,463
JS.3	0,507	0,919	0,633
JS.4	0,515	0,928	0,588
JS.5	0,410	0,793	0,394
JS.6	0,540	0,788	0,428

SE.1	0,564	0,656	0,930
SE.2	0,394	0,477	0,910
SE.4	0,486	0,463	0,847

Source: Processed primary data, SmartPLS 3.0 output (2024)

The results shown in Table 2. show the difference in factor loading values between each indicator on each variable and each indicator has a value that is greater than the target construct. Based on the results of this factor loading, it means that there are no problems with discriminant validity testing.

Table 3. Average Variance Extracted Value (AVE)

	Average Variance Extracted (AVE)	Information
Emotional Intelligence	0,619	Valid
Job Satisfaction	0,793	Valid
Self-Efficacy	0,804	Valid

Source: Processed primary data, SmartPLS 3.0 output (2024)

Based on Table 3, the AVE value for each variable is greater than 0.5, such as the emotional intelligence variable of 0.619, job satisfaction of 0.793, and self-efficacy of 0.804. It can be concluded that if the AVE value for each variable is greater than 0.5, then the research association is valid.

Reliability Test

Reliability Testing Using The SEM-PLS Approach Is Carried Out By Analyzing Criteria And Constructing Reliability. Construct reliability can be measured by considering Cronbach's Alpha and the required reliability value is 0.70. The following are reliable results:

Table 4. Composite Reliability

	Composite Reliability
Emotional Intelligence (EI)	0,919
Job Satisfaction (JS)	0,910
Self-Efficacy (SE)	0,925

Source: Processed primary data, SmartPLS 3.0 output (2024)

The results in Table 4 show that the correlation reliability value for all items is >0.7, meaning that all constructs have good reliability.

Table 5. Nilai Cronbach's Alpha

	Cronbach's Alpha
Emotional Intelligence (EI)	0,896

Job Satisfaction (JS)	0,881
Self-Efficacy (SE)	0,878

Source: Processed primary data, SmartPLS 3.0 output (2024)

The results in Table 5 show that Cronbach's Alpha for each construct is >0.7 ; This shows that the structure has good reliability.

Inner Model Analysis

Model analysis is used to test the coefficient of determination or the quality of the relationship (causal) between latent variables. The R-squared value can be used to determine how the inertial analysis of the model is calculated.

Tabel 6. Nilai R-Square

	R-Square
Job Satisfaction (JS)	0,452
Self-Efficacy (SE)	0,299

Source: Processed primary data, SmartPLS 3.0 output (2024)

Table 6 shows the R-Squer value of 0.452 for the job satisfaction construct; This means that emotional intelligence can explain 45.2% of the influence on job satisfaction, and the rest is explained by factors other than these variables. The R-Sqwer value which is also found in self-efficacy correlates 0.299. This means that self-efficacy can explain 29.9% of the relationship between emotional intelligence and job satisfaction, and the rest is explained by other factors not included in this research.

Hypothesis Test

After ensuring that the model in this research is reliable, then hypothesis testing can be carried out as shown in the following table:

Table 7. Hypothesis Test Results

Hypot hesis (H)	Variable	Origin al Sampl e (O)	T Statis tics (O/St dev)	P Value	Crite ria
H1+	EI->JS	0,349	2,958	0.003	Signi ficant
H2+	EI->SE	0,546	6,943	0.000	Signi ficant
H3+	SE->JS	0,415	3,411	0.001	Signi ficant
H4	EI->SE->JS	0.227	3,162	0.002	Signi ficant

	(Mediati on)				
--	--------------	--	--	--	--

Source: Processed primary data, SmartPLS 3.0 output (2024)

Hypothesis 1 (H1+) shows that the coefficient of the Emotional Intelligence (EI) variable has a positive influence of 2.958 on job satisfaction (JS) with a p-value < 0.003 so it is declared significant (p-value less than 0.05), the original regression coefficient is positive of 0.349. The results mean that emotional intelligence (EI) has a positive effect on job satisfaction (JS), thus hypothesis 1 is supported. Emotional Intelligence (EI) has a positive impact on teacher job satisfaction; This means that if the teacher's emotional intelligence (EI) is high, the teacher's job satisfaction (JS) will also be high.

Hypothesis 2 (H2+) shows that the path coefficient connecting the Emotional Intelligence (EI) variable of 6.943 has a positive effect on self-efficacy (SE) and the p-value is <0.000 so it is declared significant (p-value greater than 0.05 is small) , the original sample value has a positive regression coefficient of 0.546. The research results show that emotional intelligence (EI) has a positive effect on self-efficiency (SE), thus hypothesis 2 is supported. Emotional Intelligence (EI) has a positive impact on teacher effectiveness (SE); This means that if the teacher's emotional intelligence (EI) is high, the teacher's self-efficacy (SE) will also be high.

Hypothesis 3 (H3+) shows that the coefficient of the Self-Efficacy (SE) variable has a positive effect of 3.411 on Job Satisfaction (JS) and the p-value is <0.001 so it is declared significant (p-value is smaller than 0.05), and the sample value of the coefficient initial correlation of 0.415. The research results show that self-efficacy (SE) has a positive effect on job satisfaction (JS), thus hypothesis 3 is supported. self-efficacy (SE) has a positive effect on teacher job satisfaction (JS); This means that if teacher self-efficacy (SE) is high then teacher job satisfaction will also be high.

Hypothesis 4 (H4) indicates that the path coefficient between emotional intelligence (EI) and job satisfaction (JS) is related to self-efficacy (SE) with a t-statistic of 3.162 and a p-value <0.002 so it is considered significant. This shows that self-

efficacy (SE) can mediate the relationship between emotional intelligence (EI) and job satisfaction (JS), so that Hypothesis 4 is supported. Self-efficacy (SE) plays a role in the relationship between emotional intelligence (EI) and teacher job satisfaction (JS); This means that Self-Efficacy (SE) plays a role in the relationship between Emotional Intelligence (EI) and teacher performance intensity and Job Satisfaction (JS).

DISCUSSION

How Emotional Intelligence Affects Job Satisfaction

Hypothesis 1 (H1) confirms that emotional intelligence has a positive effect on job satisfaction, meaning that high teacher emotional intelligence increases teacher job satisfaction. At the Nanga Wera Village Elementary School, it shows that teachers are confident in their abilities and know their strengths and weaknesses in their work and the principal provides support and motivation to teachers so that teachers will have the ability to accept, assess, manage, and control their own emotions. and other people around him and can do his job well.

These results are in line with research conducted by (Suleman et al., 2020) & (Sökmen & Sarikaya, 2022), stating that emotional intelligence has a positive effect on job satisfaction. Emotional intelligence (EI) plays an important role in teachers' professional development, influencing their ability to effectively manage stress and emotions. Teachers with high levels of EI can recognize, understand, and regulate their own emotions, which leads to better stress management (Kanbur & Kirikkaleli, 2023).

This self-awareness allows them to navigate challenges, overcome fears, and reduce anxiety, ultimately increasing job satisfaction (Zafar & Akhtar, 2023). Research shows that emotional intelligence can be developed through specialized training, emphasizing the importance of including EI development in teacher education programs. By improving EI, teachers can improve coping strategies, social skills, decision-making, and overall quality of teaching, contributing to a positive work environment and potentially reducing teacher attrition rates. Ultimately, teachers with a deep understanding of their emotions are better prepared to handle the demands of their

profession and foster a supportive learning environment.

How Emotional Intelligence Affects Self-efficacy

Hipotesis kedua (H2) mendukung bahwa kecerdasan emosional berpengaruh positif terhadap efikasi diri; Artinya semakin tinggi kecerdasan emosional guru, maka semakin tinggi pula efikasi diri guru tersebut. At the state elementary school in Nanga Wera village, it shows that teachers are confident in their abilities and know their strengths and weaknesses in working, so by having this experience teachers will certainly not experience problems when working.

The results of this study are consistent with the research (Sökmen & Sarikaya, 2022) & (Zafar & Akhtar, 2023), which shows that emotional intelligence has a positive effect on self-efficacy. Emotional intelligence plays an important role in being an effective teacher. Teachers with high emotional intelligence can better understand and manage their emotions, thereby increasing their self-confidence and resilience when facing difficulties. Studies show that emotional intelligence positively influences teachers' performance, increasing their ability to control emotions, empathize, and adapt. Additionally, teachers with good emotional intelligence can be very good at creating a better learning environment, supporting student motivation, and encouraging success (Zafar & Akhtar, 2023). Therefore, teachers who understand their emotions well are likely to demonstrate higher levels of self-efficacy, allowing them to overcome challenges with confidence and manage their emotions better.

Self-Efficacy's Impact on Job Satisfaction

The third hypothesis (H3) supports that self-efficacy has a positive effect on job satisfaction; This means that the better the teacher's performance, the more satisfied the teacher will be with his work. At the state elementary school in Nanga Wera village, it shows that teachers have experience with their work, they also do not experience problems when working, so this will encourage them to be able to do their work well.

The findings of this study (Sökmen & Sarikaya, 2022), are consistent with research showing that self-efficacy has a positive effect on job satisfaction. People with high

self-efficacy are more motivated and committed to their work, confident in their ability to achieve goals, and successfully overcome challenges (Yentur, 2023). This belief leads them to see challenges as opportunities for growth rather than threats to their self-esteem. Enables them to set ambitious goals, persevere through adversity, and develop effective coping mechanisms. In addition, high self-efficacy is associated with increased job satisfaction because individuals feel satisfied with their progress and achievements, gaining from their work efforts (Rachma et al., 2023). Overall, the strong belief in one's abilities that comes with high self-efficacy plays an important role in increasing motivation, engagement, goal achievement, and ultimately job satisfaction in the workplace.

The Impact of Emotional Intelligence on Self-Efficacy and Job Satisfaction

Hypothesis four (H4) supports that self-efficacy can mediate the relationship between emotional intelligence and job satisfaction, which means that self-efficacy strengthens the connection between teacher job satisfaction and emotional intelligence. The public elementary school in Nanga Wera village, it shows that teachers at the Nanga Wera Village Public Elementary School show that they are confident in their abilities and know their strengths and weaknesses in their work, the principal provides support and motivation to them, they are experienced in their work, but they also do not experience problems when working, therefore they will have the ability to accept, assess, manage and control the emotions of themselves and other people around them and can carry out their duties well.

These results are in line with the research (Sökmen & Sarikaya, 2022), in which research states that self-efficacy can mediate the connection between work engagement and emotional intelligence. Emotional intelligence plays an important role in shaping individual self-efficiency (Muhammad Habib et al., 2023). High emotional intelligence allows individuals to understand and manage emotions effectively, leading to increased self-confidence in overcoming challenges and achieving goals. Individuals with strong emotional intelligence tend to have higher levels of self-efficacy, feeling better able to manage obstacles and achieve goals. This

increase in self-efficacy is often associated with increased job satisfaction because individuals who believe in their ability to succeed tend to be more motivated and committed to personal and organizational goals (Nisfary et al., 2023). Therefore, emotional intelligence not only influences self-efficacy but also contributes significantly to job satisfaction and motivation levels in individuals

CONCLUSION

Based on the results of the analysis and discussion above, this research concludes that emotional intelligence has a positive effect on job satisfaction with a p-value of 0.003. This means that the higher the teacher's emotional intelligence, the more the teacher will enjoy their work. Emotional intelligence has a positive effect on self-efficacy with a p-value of 0.000. This means that the more emotionally intelligent a teacher is, the higher the teacher's self-efficacy will be. Self-efficacy has a positive influence on job satisfaction with a p-value of 0.001. The better the efficacy, the more he enjoys his work. Self-efficacy can mediate the relationship between emotional intelligence and job satisfaction with a p-value of 0.002. This means that self-efficacy can strengthen the relationship between teacher intelligence and job satisfaction.

REFERENCES

- Abebe, D. W., & Singh, D. P. (2023). The Relationship between Emotional Intelligence, Job Satisfaction, and Job Performance: Empirical Evidence from Public Higher Education Institutions. *European Journal of Business and Management Research*, Vol.8(No.3), 45–52.
- Anh, N. T. T., & Huy, N. X. (2022). Developing Emotional Intelligence for Education Innovation in Schools. *VNU Journal of Science: Education Research*, Vol.39(No.1), 11–21. <https://doi.org/10.25073/2588-1159/vnuer.4659>
- Cabaron, G. J., & Oco, R. M. (2023). Teachers' Level of Motivation and Job Satisfaction. *Asian Journal of Education and Social Studies*, Vol.45(No.1), 1–9. <https://doi.org/10.9734/ajess/2023/v45i1971>

- Capone, V., Joshanloo, M., & Sang-Ah Park, M. (2023). Job Satisfaction Mediates the Relationship between Psychosocial and Organization Factors and Mental Well-Being in Schoolteachers. *International Journal of Environmental Research and Public Health*, Vol.20(No.1).
- Chauhan, R., Kaul, V., & Maheshwari, N. (2022). Impact of Emotional Intelligence on Job Performance of Nurses With Mediating Effect of Job Satisfaction. *Asia Pacific Journal of Health Management*, 17(2), 1–8. <https://doi.org/10.24083/apjhm.v17i2.1257>
- Creswell, J. W., & Creswell, J. D. (2017). (2017). *Research design: Qualitative, quantitative, and mixed methods approaches*. Sage publications. (4th ed.). Sage Publications.
- Feng, X., Helms-Lorenz, M., & Maulana, R. (2023). Teachers' intrinsic orientation, self-efficacy, background characteristics, and effective teaching: A multilevel moderated mediation modeling. In *Effective Teaching Around the World: Theoretical, Empirical, Methodological and Practical Insights* (pp. 543–574). Department of Teacher Education, University of Groningen, Groningen, The Netherlands e-mail: https://doi.org/10.1007/978-3-031-31678-4_24
- Igbokwe, I. C., Egboka, P. N., Thompson, C. C., Etele, A. V., Anyanwu, A. N., Okeke-James, N. J., & Uzoekwe, H. E. (2023). Emotional Intelligence: Practices to Manage and Develop It. In *European Journal of Theoretical and Applied Sciences: Vol. Vol.1* (Issue No.4).
- Kanbur, O., & Kirikkaleli, N. O. (2023). Interaction between teachers' emotional intelligence and classroom management. *Perspectives in Education*, Vol.41(No.2), 3–15. <https://doi.org/10.38140/pie.v41i2.6847>
- Lingán-Huamán, S. K. et al. (2023). Teacher self-efficacy: development, validity, and factorial invariance of a brief measure in Peruvian university professors. *Frontiers in Education*, Vol.8(July), 1–8. <https://doi.org/10.3389/educ.2023.1211487>
- McJames, N., Parnell, A., & O'Shea, A. (2023). Factors affecting teacher job satisfaction: a causal inference machine learning approach using data from TALIS 2018. *Educational Review*, 0(0), 1–25. <https://doi.org/10.1080/00131911.2023.2200594>
- Muhammad Habib, Syed Muhammad Ali Naqi, & Mohsan Ali. (2023). Emotional Intelligence: Understanding, Assessing, and Cultivating the Key to Personal and Professional Success. *Sir Syed Journal of Education & Social Research*, Vol.6(No.2), 50–55. [https://doi.org/10.36902/sjesr-vol6-iss2-2023\(50-55\)](https://doi.org/10.36902/sjesr-vol6-iss2-2023(50-55))
- N. Valente, S., A. Lourenço, A., & Dominguez-Lara, S. (2022). *Teachers in the 21st Century: Emotional Intelligence Skills Make the Difference* (pp. 1–15). <https://doi.org/10.5772/intechopen.103082>
- Nicolae Brînzea. (2022). Emotional intelligence, the ability to access or generate feelings. *Technium Social Sciences Journal*, 6(Oktober), 570–575.
- Nisfary, R. K., Sulistyaningsih, W., Minauli, I., & Hermawati, T. (2023). The Relationship of Emotional Intelligence and Self-Efficacy with Academic Procrastination in Student. *Al Hikmah: Journal of Education*, 4(1), 13–36. <https://doi.org/10.54168/ahje.v4i1.149>
- P. Sampan, F., & G. Caballes, D. (2023). Sense of Efficacy and Burnout among General and Special Needs Education Teachers. *Journal of Humanities and Education Development*, Vol.5(No.3), 102–105. <https://doi.org/10.22161/jhed.5.3.13>
- Rachma, B., Budiman, & Perdana, R. (2023). Efikasi Diri dan Tingkat Stres pada Pelajar SMA Negeri 1 Cibitung Selama Pembelajaran di masa Pandemi Covid-19. *Bandung Conference Series: Medical Science*, 3(1), 593–599. <https://doi.org/10.29313/bcsms.v3i1.6341>
- Sharief, S. (2022). Relationship between emotional intelligence and stress among university going students of Kashmir. *International Journal of Psychology Sciences*, Vol.4(No.1), 01–06. <https://doi.org/10.33545/27068919.2021.v3.i3d.980>
- Sökmen, Y., & Sarikaya, İ. (2022). The mediating role of self-efficacy between emotional intelligence and job satisfaction of primary school teachers. *Revue Européenne de Psychologie Appliquée*, 72(4). <https://doi.org/10.1016/j.erap.2022.100779>
- Suleman, Q., Syed, M. A., Mahmood, Z., & Hussain, I. (2020). Correlating Emotional Intelligence With Job Satisfaction: Evidence From a Cross-Sectional Study Among Secondary School Heads in Khyber Pakhtunkhwa, Pakistan. *Frontiers in Psychology*, 11(March), 1–14. <https://doi.org/10.3389/fpsyg.2020.00240>
- Syamsu, A. (2017). Self-Efficacy: a New Research Construct in Indonesian English Teachers

Study. *ETERNAL (English, Teaching, Learning and Research Journal)*, Vol.3(No.2), 119–124.
<https://doi.org/10.24252/eternal.v32.2017.a1>

- Tcharkhalashvili, T. (2023). The role of Emotional Intelligence in Creating and Managing an Effective Learning Environment. *Transactions of Telavi State University*.
- Tirana, J., Trungu, D., & Chiesi, L. L. (2023). Motivation Factors Influence Teachers' Job Satisfaction. *Journal of Educational and Social Research*, 13(3), 265–272.
<https://doi.org/10.36941/jesr-2023-0075>
- Yentur, M. M. (2023). The Effect of Geography Teachers' Self-Efficacy Perceptions and Attitudes Toward Teaching on Motivation. *International Journal of Educational Research Review*, Vol.8(No.2), 360–367.
<https://doi.org/10.24331/ijere.1255100>
- Zafar, J. M., & Akhtar, M. S. (2023). Emotional Intelligence and Anxiety Handling in Secondary Grade Students by Classroom Managerial Style. *Academy of Education and Social Sciences Review*, 3(1), 22–31.
<https://doi.org/10.48112/aessr.v3i1.399>